



# DELUGE VALVE, AUTOMATIC RESETTING, 2-1/2 INCH (65 mm)

## MODEL F446 (THREAD x THREAD or GROOVE X GROOVE) — 250 PSI (17,2 bar)

### Port Locations:

- A - 2-1/2" NPT Inlet
- B - 2-1/2" NPT Outlet
- C - 1-1/4" NPT Main Drain
- D - 1/2" NPT Alarm & Auxiliary Drain
- E - 1/2" NPT Diaphragm Supply & Diaphragm Chamber Pressure Gauge
- F - 1/2" NPT Alarm Test or Water Supply Pressure Gauge
- G - 1/2" NPT Alarm Test or Water Supply Pressure Gauge

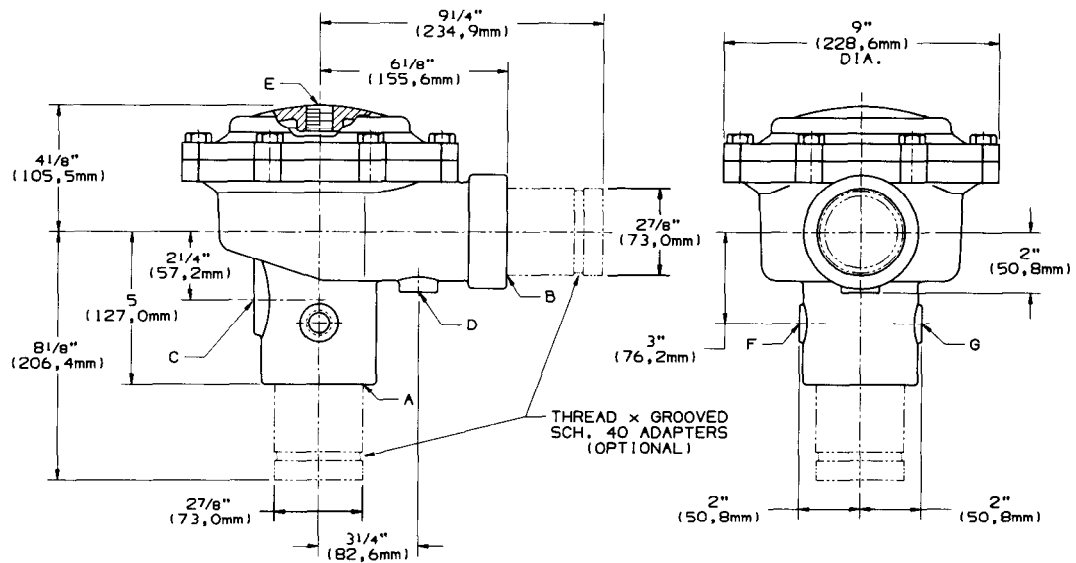

**FIGURE A**  
**MODEL F446 AUTOMATIC RESETTING DELUGE VALVE**  
**THREAD x THREAD or GROOVE x GROOVE**  
**— DIMENSIONS AND PORT LOCATIONS —**

### GENERAL DESCRIPTION

The 250 psi (17,2 bar), 2-1/2 inch (65mm), Model F446 Automatic Resetting Deluge Valve is a quick opening, hydraulically operated differential type valve designed for fire protection system service. It is used as an "automatic water control valve" in a deluge fire protection system. The F446 Valve also provides for actuation of fire alarms upon system operation.

The automatic resetting feature of the F446 provides for easy, external resetting of a deluge system, without having to open a valve handhole cover to manually reposition a clapper and latch mechanism.

Operation of the F446 Valve is provided by an actuation (detection) system that is separate from the normally dry system piping. The trim configuration of the F446 is for automatic electric actuation. The trim arrangement also provides for local emergency (manual) release of the F446 Valve.

The compact and easily installed trim arrangement has been designed so that the F446 Valve may be installed for either "flow left" or "flow right".

### APPROVALS AND STANDARDS

The 250 psi (17,2 bar), 2-1/2 inch (65mm), Model F446 Automatic Resetting Deluge Valve is listed by Underwriters Laboratories Inc. and Underwriters' Laboratories of Canada. The F446 Valve is also approved by Factory Mutual Research Corporation.

#### WARNING

*The Model F446 Deluge Valve described herein must be installed and maintained in compliance with this document, as well as with the applicable standards of the National Fire Protection Association, in addition to the standards of any other authorities having jurisdiction. Failure to do so may impair the integrity of this device.*

*The owner is responsible for maintaining their fire protection system and devices in proper operating condition. The installing contractor or manufacturer should be contacted relative to any questions.*

### TECHNICAL DATA

#### Deluge Valve:

The 250 psi (17,2 bar), 2-1/2 inch (65mm), Model F446 Automatic Resetting Deluge Valve is rated for use at a maximum service pressure of 250 psi (17,2 bar). The Valve dimensions are shown in Figure A, and all of the ports are NPT threaded per ANSI Standard B1.20.1. Grooved end connections are cut in accordance with Gruvlok standard groove specifications for steel pipe, and they are suitable for use with grooved end pipe couplings that are listed or approved for fire protection system service.

The F446 Valve is to be installed vertically, as shown in Figure A, with the inlet connection at the bottom and the outlet connection to the side. Exterior surfaces of the F446 Valve are painted red, and the year of manufacture is indicated on the Cover.

Components of the F446 Valve are shown in Figure B. The Body and Cover are ductile iron per ASTM A536, Grade 65-45-12 (UNS F33100). Both the Diaphragm and Facing are EPDM.

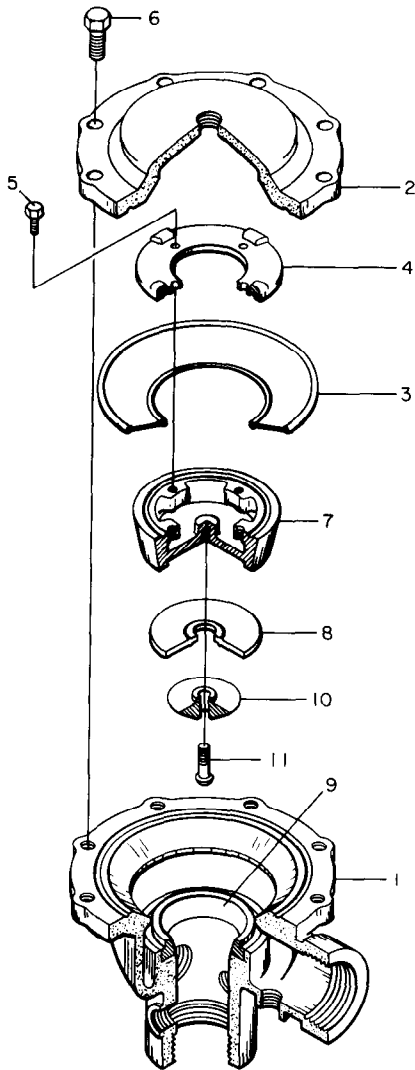

- |  |                                |
|--|--------------------------------|
| 1 - Body   | 6 - Cap Screw,<br>1/2\"-13 UNC |
| 2 - Cover  | 7 - Center Valve               |
| 3 - Diaphragm  | 8 - Facing                     |
| 4 - Diaphragm<br>Ring                                  | 9 - Seat Ring                  |
| 5 - Cap Screw,<br>1/4\"-20 UNC<br>x 3/4\"<br>(4 req'd) | 10 - Facing Retainer           |
|  | 11 - Retainer Screw            |

**FIGURE B**  
**MODEL F446 AUTOMATIC**  
**RESETTING DELUGE VALVE**  
**— ASSEMBLY —**

The Diaphragm Ring and Center Valve are bronze per ASTM B62 (UNS C83600), and the Seat Ring is brass per ASTM B584 (UNS C84400 or C83600). The Facing Retainer is brass per ASTM B584 (UNS C84400). The Cap Screws and Facing Retainer Screw are Type 303 stainless steel.

The nominal pressure loss versus flow is shown in Graph A-1 and A-2. The approximate friction loss, based on the Hazen and Williams formula and expressed in equivalent length of Schedule 40 pipe with C = 120, is 10 feet. The equivalent length of pipe has been cal-

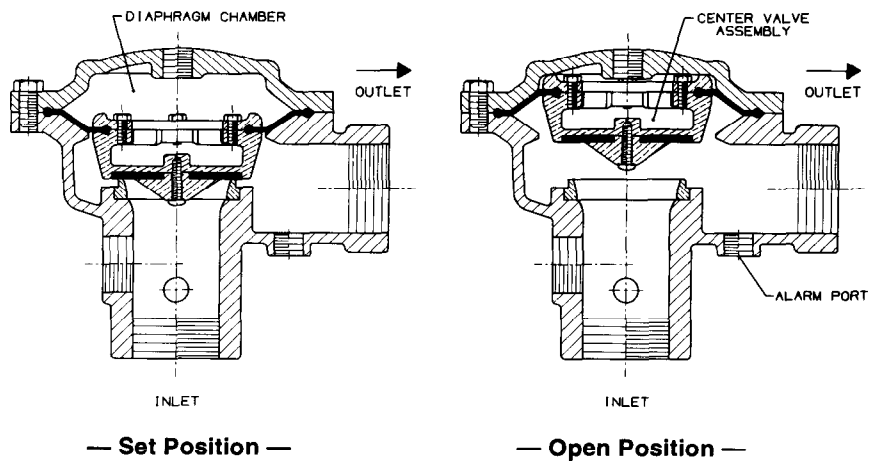

**FIGURE C**  
**MODEL F446 AUTOMATIC RESETTING DELUGE VALVE**  
**— SET AND OPEN POSITIONS —**

culated on the basis of flow rates typically used with a 2-1/2 inch (65 mm) size valve.

**Valve Trim:**

The Electric Actuation Trim is required for electric operation of the F446 Valve by a detection system consisting of electrical devices such as heat sensitive thermostats, smoke detectors, and/or electric manual pull stations. A listed and approved, 24VDC, 0.92 Amp, NEMA 2, 3, 4, 4X rated, Solenoid Valve for 250 psi (17,2 bar), non-hazardous locations is supplied as standard. Nominal installation dimensions for the Electric Actuation Trim are shown in Figure D.

The Electric Actuation Trim (Ref. Figure F) forms a part of the laboratory listings and approval of the F446 Valve and are necessary for proper operation of the F446 Valve. The trim package, may be installed on the F446 Valve with either "flow left" or "flow right", and the package includes the following items:

- Water Supply Pressure Gauge
- Diaphragm Chamber Pressure Gauge
- Diaphragm Chamber Connections
- Actuation Devices
- Main Drain Valve
- Alarm Test Valve
- Alarm Control Valve
- Automatic Drain Valve

The Electric Actuation Trim is only to be used in conjunction with an electric deluge valve releasing panel (automatic control unit) that is listed or approved (as appropriate) for fire protection system releasing service. In addition, the deluge valve releasing

panel is only to be operated by listed or approved (as appropriate) fire detectors.

Operation of an electrical device such as heat sensitive thermostat, smoke detector, or electric manual pull station signals the deluge valve releasing panel to energize the Solenoid Valve. In turn, the energized Solenoid Valve opens resulting in a rapid pressure drop in the Diaphragm Chamber of the F446 Valve, and the force differential holding the F446 Valve in the set position is eliminated.

**NOTES**

*Consult with the Authority Having Jurisdiction regarding installation criteria pertaining to electric actuation circuitry.*

*Once energized, the Solenoid Valve must remain energized in order for the F446 Valve to remain open.*

**OPERATING PRINCIPLES**

The F446 Valve is a differential valve which depends upon water pressure in the Diaphragm Chamber (Ref. Figure C) to hold the Center Valve Assembly closed against the water supply pressure. The nominal trip ratio is 2.5 to 1, i.e., the F446 Valve operates (opens) when the pressure in the Diaphragm Chamber is reduced to approximately two-fifths of the water supply pressure.

When the F446 Valve is set for service, the Diaphragm Chamber is pressurized through the trim connections from the inlet side of the system's main control valve, for example an O.S.&Y. gate valve or butterfly valve (Ref. Fig. E).

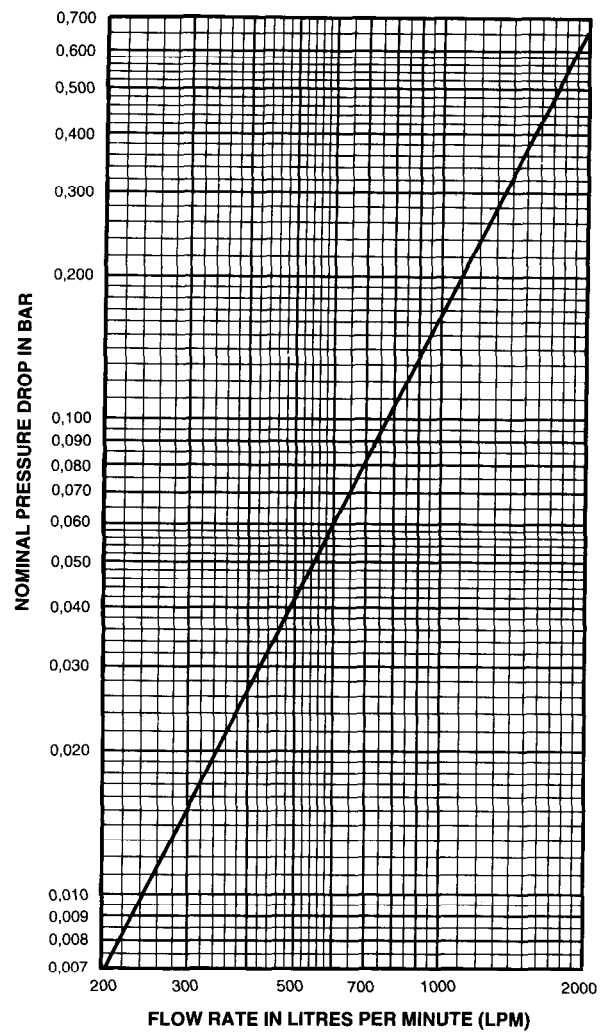
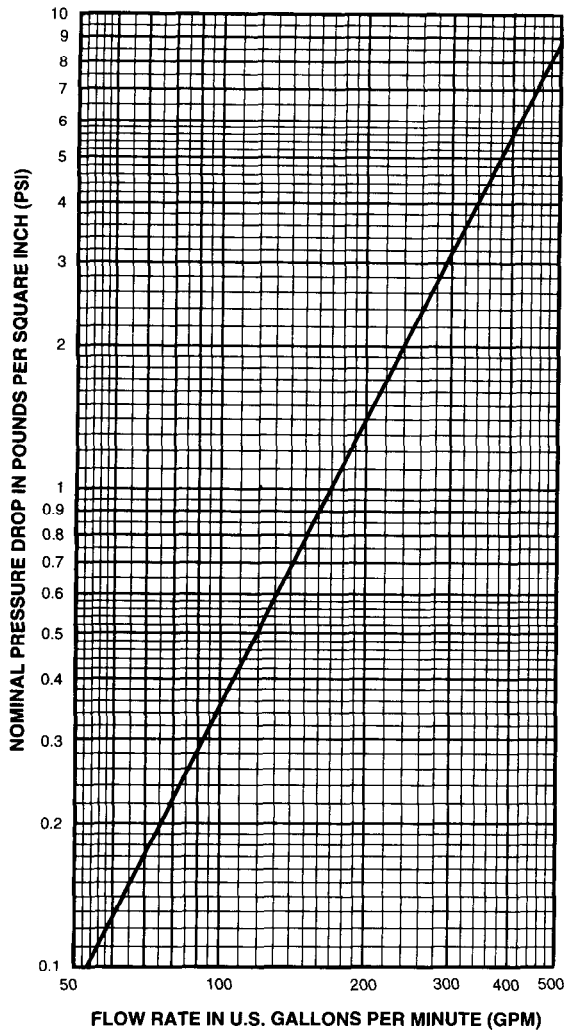

1 Bar = 100 kPa

**GRAPH A-1 and A-2  
NOMINAL PRESSURE LOSS VERSUS FLOW**

Opening of the solenoid valve in the Electric Actuation Trim (Ref. Fig. E), releases water from the Diaphragm Chamber faster than it can be replenished through the 1/8" (3.2 mm) Restriction in the Diaphragm Chamber Supply Connection. This results in a rapid pressure drop in the Diaphragm Chamber and the force differential holding the Center Valve Assembly down in the set position is eliminated. The water supply pressure then forces the Center Valve Assembly open permitting water to flow into the system piping, as well as through the Alarm Port to actuate system alarms (Ref. Figure C).

**NOTE**

Once the solenoid valve or manual control station is opened to operate the F446 Valve, the actuation device must remain open in order for the F446 Valve to remain open.

**INSTALLATION**

**NOTES**

Proper operation of the Model F446 Deluge Valve depends upon its trim being installed in accordance with the instructions given in this Technical Data Sheet. Failure to follow the appropriate trim diagram may prevent the F446 Valve from functioning properly, as well as void listings, approvals, and the manufacturer's warranties.

The F446 Valve must be installed in a readily visible and accessible location.

The F446 Valve, associated trim, and wet pilot lines must be maintained at a minimum temperature of 40°F/4°C.

Heat tracing of the F446 Valve or its associated trim is not permitted. Heat

tracing can result in the formation of hardened mineral deposits which are capable of preventing proper operation.

The F446 Valve is to be installed in accordance with the following criteria:

1. All nipples, fittings, and devices must be clean and free of scale and burrs before installation. Use pipe thread sealant sparingly on male pipe threads only.
2. The F446 Valve must be trimmed in accordance with Figure F.
3. Care must be taken to make sure that check valves, strainers, globe valves, etc. are installed with the flow arrows in the proper direction.
4. Drain tubing to the drip funnel must

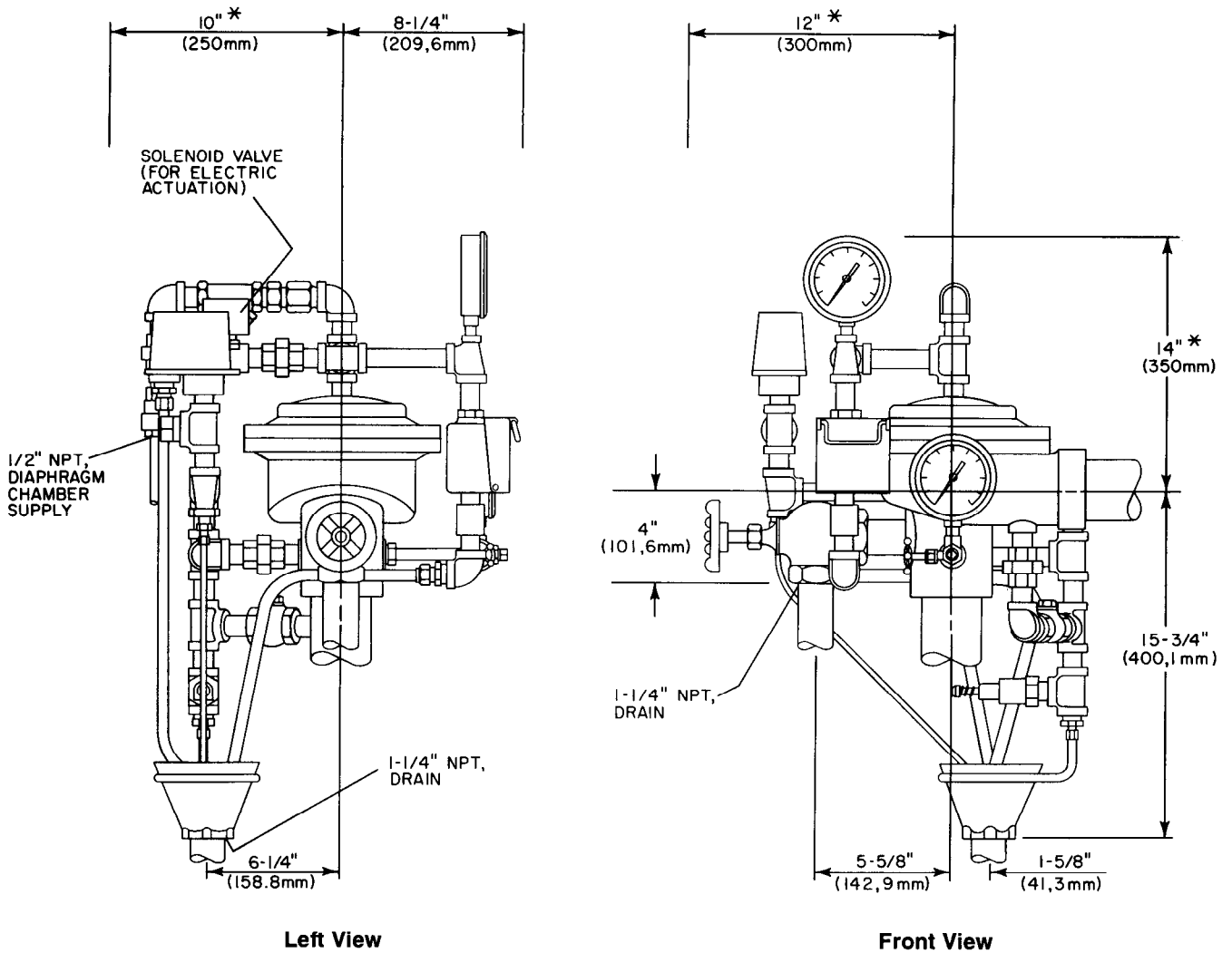

**FIGURE D**  
**NOMINAL INSTALLATION DIMENSIONS FOR**  
**ELECTRIC ACTUATION TRIM**

\* MINIMUM CLEARANCE, ADDITIONAL 2" (50 mm) RECOMMENDED

be installed with smooth bends that will not restrict flow.

5. The main drain and drip funnel drain may be interconnected provided a check valve is located at least 12 inches (300mm) below the drip funnel.
6. Suitable provision must be made for disposal of drain water. Drainage water must be directed such that it will not cause accidental damage to property or danger to persons.
7. Connect the Diaphragm Chamber Supply Control Valve to the inlet side of the system's main control valve in order to facilitate setting of the F446.
8. Unused pressure alarm switch connections must be plugged.
9. Conduit and electrical connections are to be made in accordance with

the requirements of the authority having jurisdiction and/or the National Electric Code.

#### VALVE SETTING PROCEDURE

Steps 1 through 11 are to be performed when initially setting the F446 Valve; after an operational test of the fire sprinkler system; or, after system operation due to a fire.

1. Close the Diaphragm Chamber Supply Control Valve.
2. Close the Main Control Valve.
3. Open the Main Drain Valve and all auxiliary drains in the system. Close the auxiliary drain valves after water ceases to discharge. Leave the Main Drain Valve open.
4. Depress the plunger of the Automatic Drain Valve to verify that it is open and that the F446 Valve is completely drained.

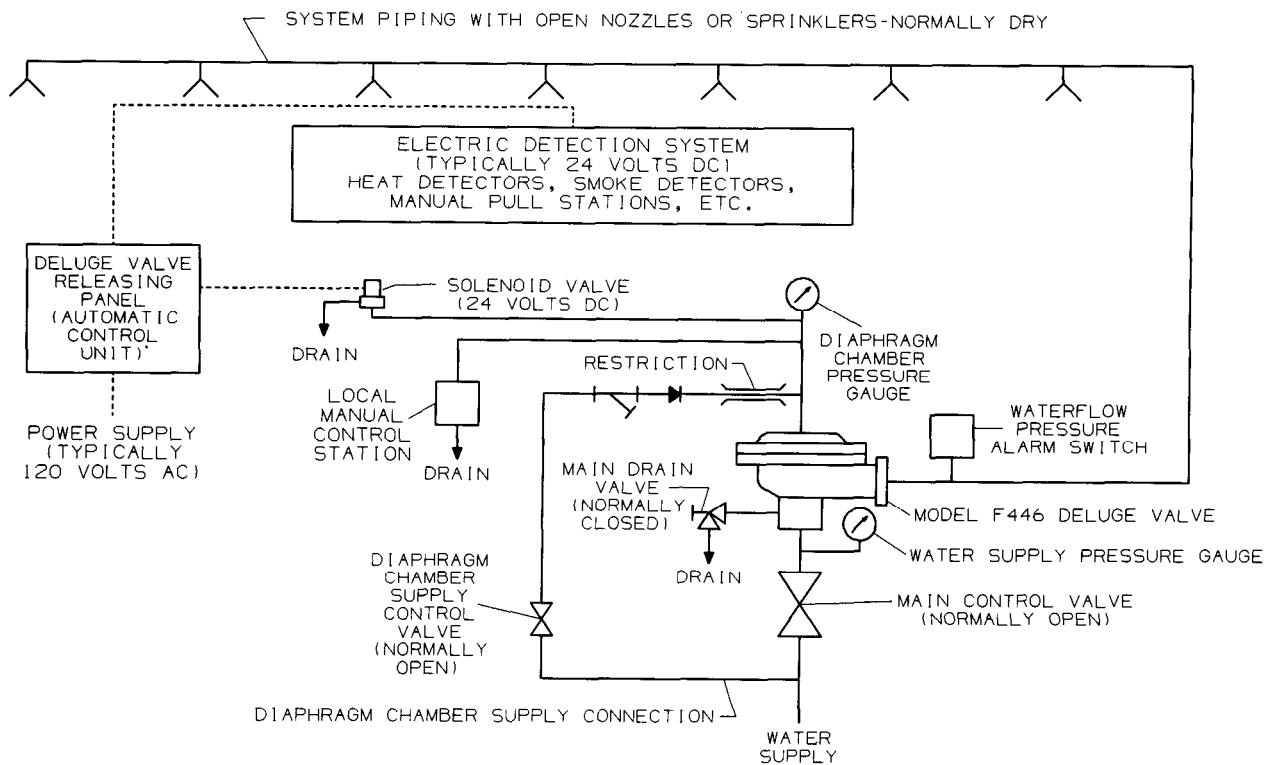

**FIGURE E**  
**DELUGE VALVE SYSTEM SCHEMATIC**  
**— ELECTRIC ACTUATION —**

5. Clean the Strainer in the Diaphragm Chamber Supply connection by removing the clean-out plug and strainer basket. The Strainer may be flushed out by momentarily opening the Diaphragm Chamber Supply Control Valve.
6. Reset the actuation system.
 

Manual Actuation — Push the operating lever up; however, do not close the hinged cover at this time.

Electric Actuation — Reset the electric detection system in accordance with the manufacturer's instructions to de-energize the solenoid valve.
7. Open the Diaphragm Chamber Supply Control Valve and allow time for full pressure to build up in the Diaphragm Chamber.
8. Operate (open) the Manual Control Station to vent trapped air from the Diaphragm Chamber. If necessary, first open the hinged cover, and then fully pull down on the operating lever. SLOWLY close the operating lever, by pushing it up, after aerated water ceases to discharge from the Manual Control Station drain tubing. Close the hinged cover and insert a new break rod in the small hole through the top of the enclosing box.
9. Inspect drain connections from the Manual Control Station and Solenoid Valve. Any leaks must be corrected before proceeding to the next step.
10. Slowly open the Main Control Valve. Close the Main Drain Valve as soon as water discharges from the drain connection. Observe the Automatic Drain Valve for leaks. If there are leaks, determine/correct the cause of the leakage problem. If there are no leaks, the F446 Valve is ready to be placed in service and the Main Control Valve must then be fully opened.
11. Open the Alarm Control Valve.
 

It is recommended that the Alarm Control Valve be wired sealed in the open position with a No. 16 twisted wire, the ends of which are secured by a lead seal. The wire seal should be looped through the hole in the handle and tightly twisted around the pipe nipple at the outlet of the Alarm Control Valve.

**NOTE**

*After setting a fire protection system, notify the proper authorities and advise those responsible for monitoring proprietary and/or central station alarms.*

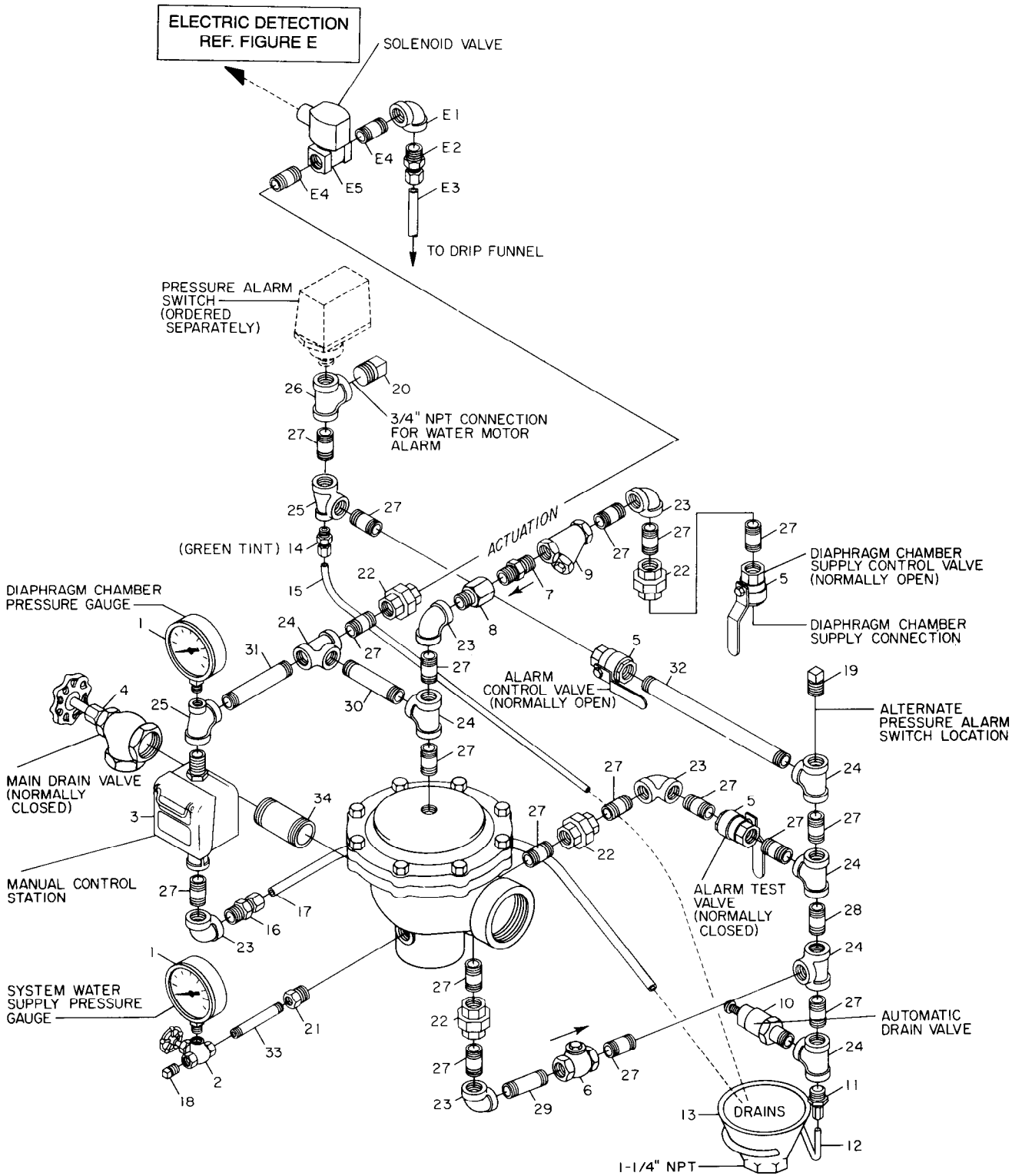

**FIGURE F**  
**VALVE TRIM ASSEMBLY**

- |  |                                     |
|--|-------------------------------------|
| 1 - 300 lb. Water Pressure Gauge (2 req'd) | 28 - 1/2" x 2" Nipple               |
| 2 - 1/4" Gauge Test Valve                  | 29 - 1/2" x 2" Nipple               |
| 3 - Model F180 Manual Control Station      | 30 - 1/2" x 3-1/2" Nipple           |
| 4 - 1-1/4" Angle Valve                     | 31 - 1/2" x 4-1/2" Nipple           |
| 5 - 1/2" Ball Valve (3 req'd)              | 32 - 1/2" x 10-1/2" Nipple          |
| 6 - 1/2" Swing Check Valve                 | 33 - 1/4" x 3" Nipple               |
| 7 - 1/2" Spring Loaded Check Valve         | 34 - 1-1/4" x 3" Nipple             |
| 8 - Priming Supply Restriction             | E1 - 1/2" 90° Elbow                 |
| 9 - 1/2" Y-Strainer                        | E2 - 1/2" Tube Connector            |
| 10 - Model F793 Automatic Drain Valve      | E3 - 1/2" Tube, 24" long            |
| 11 - Drip Funnel Support Plug              | E4 - 1/2" x 1-1/2" Nipple (2 req'd) |
| 12 - Drip Funnel Support                   | E5 - 24VDC Solenoid Valve           |
| 13 - Drip Funnel                           |                                     |
| 14 - 3/32" Vent Fitting                    |                                     |
| 15 - 1/4" Tube, 24" long                   |                                     |
| 16 - 1/2" Tube Connector                   |                                     |
| 17 - 1/2" Tube, 24" long                   |                                     |
| 18 - 1/4" Plug                             |                                     |
| 19 - 1/2" Plug                             |                                     |
| 20 - 3/4" Plug                             |                                     |
| 21 - 1/2" x 1/4" Bushing                   |                                     |
| 22 - 1/2" Union (4 req'd)                  |                                     |
| 23 - 1/2" 90° Elbow (5 req'd)              |                                     |
| 24 - 1/2" Tee (6 req'd)                    |                                     |
| 25 - 1/2" x 1/4" x 1/2" Tee (2 req'd)      |                                     |
| 26 - 1/2" x 1/2" x 3/4" Tee                |                                     |
| 27 - 1/2" x 1-1/2" Nipple (18 req'd)       |                                     |

#### NOTES:

- Electric Actuation Trim** consists of Items 1 through 34 plus E1 through E5.
- The illustrated arrangement, shown on Page 6, is for "Flow Right". A "Flow Left" arrangement can be obtained using the same bill of materials.
- The nipples utilized in the trim arrangements are Schedule 40 steel per ASTM A53 or A135 and they are threaded per ANSI B1.20.1. Fittings are malleable iron per ANSI B16.3.

"Standard order" trim is provided with black nipples and fittings; however, galvanized nipples and fittings are available on "special order".

**FIGURE F  
VALVE TRIM ASSEMBLY**

## CARE AND MAINTENANCE

The following procedures and inspections should be performed as indicated, in addition to any specific requirements of the NFPA, and any impairment must be immediately corrected. It is also recommended that fire protection systems be inspected by a qualified Inspection Service.

#### NOTES

*The operational test procedure and waterflow pressure alarm test procedure will result in operation of the associated alarms. Consequently, notification must be given to the owner and the fire department, central station, or other signal station to which the alarms are connected.*

*Before closing a fire protection system main control valve for maintenance work on the fire protection system which it controls, permission to shut down the effected fire protection systems must first be obtained from the proper authorities and all personnel who may be affected by this decision must be notified.*

#### Annual Operation Test Procedure

Proper operation of the F446 Valve (i.e., opening of the F446 Valve as during a fire condition) should be verified at least once a year as follows:

- If water must be prevented from flowing beyond the riser, perform the following steps.
  - Close the Main Control Valve.
  - Open the Main Drain Valve.
  - Open the Main Control Valve one turn beyond the position at which water just begins to flow from the Main Drain Valve.
  - Close the Main Drain Valve.
- Operate the F446 Valve by energizing the solenoid valve via testing the deluge releasing panel (automatic control unit) in accordance with the manufacturer's instructions.

#### NOTE

*Be prepared to quickly perform Steps 3, 4, and 5, if water must be prevented from flowing beyond the riser.*

- Verify that the F446 Valve has tripped, as indicated by the flow of water into the system.
- Close the Diaphragm Chamber Supply Control Valve.

- Close the system's Main Control Valve.
- Reset the F446 Deluge Valve in accordance with the Valve Setting Procedure.

#### Five Year Internal Valve Inspection

Once every five years during the annual operation procedure and prior to the F446 Valve being reset, the internal parts of the F446 valve should be cleaned and inspected for wear and damage. Special consideration should be given to the condition of the Diaphragm. The Diaphragm should be replaced if there are any sign of deterioration due to age or chemicals in the water. If the water supply contains chemicals which tend to attack an EPDM type rubber, then the frequency of the Diaphragm inspection should be increased to at least annually.

Worn or damaged parts must be replaced and the F446 Valve must be reassembled in accordance with Figure B. The Cap Screws securing the Cover should be uniformly tightened using a cross-draw sequence.

#### Quarterly Solenoid Valve Test Procedure For Electric Actuation

Proper operation of the Solenoid Valve for electric actuation should be verified at least quarterly as follows:

- Close the Main Control Valve.
- Open the Main Drain Valve.
- Test the deluge valve releasing panel (automatic control unit) in accordance with the manufacturer's instructions to energize the solenoid valve.
- Verify that the flow of water from the Solenoid Valve drain connection increases to a full flow.
- Verify that the Diaphragm Chamber pressure has decreased to below 25% of the water supply pressure.
- Reset the electric detection system in accordance with the manufacturer's instructions to de-energize the solenoid valve. Check the Solenoid Valve drain for leaks. Any leaks must be corrected before proceeding to the next step.
- Slowly open the Main Control Valve. Close the Main Drain Valve as soon as water discharges from the drain connection. Observe the Automatic Drain Valve for leaks. If there are leaks, determine/correct the cause

of the leakage problem. If there are no leaks, the F446 Valve is ready to be placed in service and the Main Control Valve must then be fully opened.

### Quarterly Waterflow Alarm Test Procedure

Testing of the the system waterflow alarms should be performed quarterly. To test the waterflow alarm, open the Alarm Test Valve, which will allow a flow of water to the Pressure Alarm Switch and/or Water Motor Alarm. Upon satisfactory completion of the test, close the Alarm Test Valve.

### WARRANTY

Seller warrants for a period of one year from the date of shipment (warranty period) that the products furnished hereunder will be free from defects in material and workmanship.

For further details on Warranty, see Price List.

### ORDERING PROCEDURE

All orders for Model F446 Valves, trim, accessories, and replacement parts must include the description and Product Symbol Number (PSN).

#### Valves:

Specify: 250 psi (17,2 bar), 2-1/2 inch, (specify Thread x Thread or Groove x Groove), Model F446 Automatic Resetting Deluge Valve, PSN (specify).

Thread x Thread ..... PSN 52-446-1-001  
Groove x Groove ..... PSN 52-446-1-002

#### "Standard Order" Black Trim:

Specify: Black Electric Actuation Trim for use with the Model F446 Automatic Resetting Deluge Valve, PSN 52-446-1-103.

#### "Special Order" Galvanized Trim:

Specify: Galvanized Electric Actuation Trim for use with the Model F446 Automatic Resetting Deluge Valve, PSN 52-446-2-103.

#### Accessories:

Refer to the following Technical Data Sheet (TD).

Pressure Alarm Switch ..... TD213

#### Replacement Valve Parts (Fig. B):

Specify: (description) for use with Model F446 Automatic Resetting Deluge Valve, PSN (specify).

2 - Cover ..... PSN 92-446-1-002  
3 - Diaphragm ..... PSN 92-445-1-003  
4 - Diaphragm Ring ..... PSN 92-445-1-004  
5 - Cap Screw,  
1/4"-20 UNC  
x 3/4" ..... PSN 62-634-1-104  
6 - Cap Screw,  
1/2"-13 UNC  
x 7/8" ..... PSN 62-634-1-111  
7 - Center Valve ..... PSN 92-445-1-005  
8 - Facing ..... PSN 92-445-1-006  
10 - Facing Retainer ..... PSN 92-445-1-008  
11 - Retainer Screw ..... PSN 62-679-1-012

#### Replacement Trim Parts (Fig. F):

Specify: (description) for use with Model F445 Automatic Resetting Deluge Valve, PSN (specify).

1 - 600 lb. Water Pressure Gauge ..... PSN 92-343-1-004  
2 - 1/4" Gauge Test Valve ..... PSN 46-005-1-002  
3 - F180 Manual Control Station ..... PSN 52-289-1-001  
4 - 1-1/4" Angle Valve ..... PSN 46-046-1-007  
5 - 1/2" Ball Valve ..... PSN 46-050-1-004  
6 - 1/2" Swing Check Valve ..... PSN 46-062-1-004  
7 - 1/2" Spring Loaded Check Valve ..... PSN 92-322-1-002  
8 - Priming Supply Restriction ..... PSN 92-020-1-009  
9 - 1/2" Y-Strainer ..... PSN 52-353-1-005  
10 - F793 Automatic Drain Valve ..... PSN 52-793-1-004  
11 - Drip Funnel Support Plug ..... PSN 92-211-1-005  
12 - Drip Funnel Support ..... PSN 92-211-1-003  
13 - Drip Funnel ..... PSN 92-343-1-007  
14 - 3/32" Vent Fitting ..... PSN 92-032-1-002  
E5 - 24VDC Solenoid Valve ..... PSN 52-287-1-124

### WEIGHTS

The following are the nominal weights for the valves and trim:

2-1/2" Thread x Thread Model F446 Deluge Valve ... 41 lbs. (18,6 kg)  
2-1/2" Groove x Groove Model F446 Deluge Valve ... 44 lbs. (20,0 kg)  
Electric Actuation Trim With 24VDC Solenoid Valve .. 27 lbs. (12,2 kg)